

Art. "D" - SHUTTLE ANGLE VALVE



DESCRIPTION

Valve with flat shutter closing.
 Seal: NBR - FPM - EPDM - PTFE (PTFE+FPM).
 Perfect airtight.
 Pneumatic actuator with reciprocating piston movement.
 POSITIONING RING NUT, which, turning the cylinder by 360°, allows the desired positioning of air side connection.

Connections with inner GAS ISO 228 thread female-female.

On request with NPT connections.

Control air 1/8" GAS connections.

ALLOWABLE TEMPERATURES

Operating temperature:
 Seal in NBR: from -20°C to +100°C
 Seal in FPM: from -15°C to +150°C
 Seal in EPDM: from -40°C to +100°C

ACTUATOR PILOT PRESSURE: Max 8 bar

VERSIONS AND SIZES

DA: 1/2" - 3/4" - 1" - 1"1/4 - 1"1/2 - 2" - 2"1/2 - 3"
 SANC: 1/2" - 3/4" - 1" - 1"1/4 - 1"1/2 - 2" - 2"1/2 - 3"
 SANO: 1/2" - 3/4" - 1" - 1"1/4 - 1"1/2 - 2"

**ANODIZING TREATMENT ON OUTSIDE DETAILS
 MADE IN ALUMINIUM**

It is **not subject** to the "Water Hammer" if the fluid pass through the valve in the direction of the arrow printed on the body (under the actuator).
 With these conditions the tightness is guaranteed up to the pressures shown in the Differential Pressure Chart.

MINIMUM PRESSURE REQUIRED TO OPEN NC VERSION								
G	1/2"	3/4"	1"	1"1/4	1"1/2	2"	2"1/2	3"
BAR	4	4	5	5	5	5	5	5

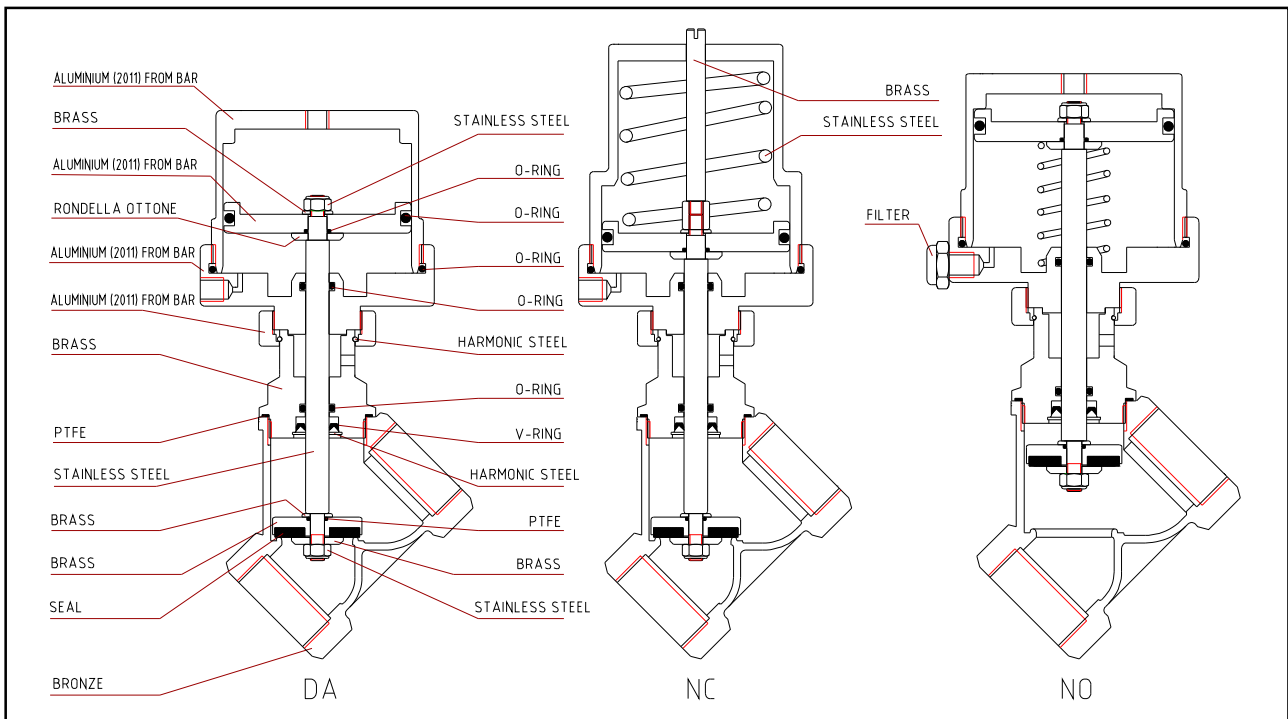
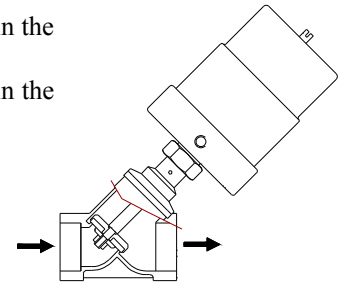

Art. "D"

DIFFERENTIAL PRESSURE CHARTE

NC : NBR-FPM-EPDM

NC : PTFE

DA/NO : NBR-FPM-EPDM

DA/NO : PTFE

G	DeltaP bar
1/2"	24
3/4"	20
1"	18
1"1/4	18
1"1/2	15
2"	9
2"1/2	4
3"	3

G	DeltaP bar
1/2"	22
3/4"	20
1"	16
1"1/4	15
1"1/2	13
2"	7
2"1/2	3
3"	2

G	PILOT PRESS.	DeltaP bar
1/2"	3	14
1/2"	4	20
3/4"	3	13
3/4"	4	19
1"	3	10
1"	4	18
1"1/4	3	15
1"1/4	4	20
1"1/2	3	12
1"1/2	4	15
2"	3	8
2"	4	10
2"1/2	4	6
2"1/2	5	8
3"	4	4
3"	5	6

G	PILOT PRESS.	DeltaP bar
1/2"	3	12
1/2"	4	18
3/4"	3	11
3/4"	4	16
1"	3	8
1"	4	15
1"1/4	3	12
1"1/4	4	18
1"1/2	3	10
1"1/2	4	13
2"	3	7
2"	4	9
2"1/2	4	5
2"1/2	5	7
3"	4	3
3"	5	5

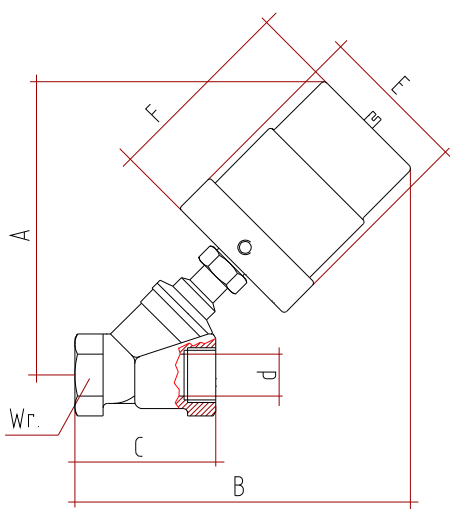

OVERALL DIMENSIONS DA/NO VERSIONS

DN	G	A	B	C	d	E	F	Wrench	Kv	Weight
mm.		mm.	mm.	mm.	mm.	mm.	mm.	mm.	m3/h	g.
15	1/2"	126	145	61	15	65	76	27	4.5	850
20	3/4"	132	152	70	20	65	76	33	11	900
25	1"	134	157	81	25	65	76	38	13	1000
32	1"1/4	167	195	95	32	100	83	49	30	1650
40	1"1/2	174	202	110	40	100	83	56	42	2100
50	2"	186	222	130	50	100	83	69	66	2950
65	2"1/2	220	230	149	65	100	86	86	82	5200
80	3"	228	248	174	80	100	86	110	98	6150

OVERALL DIMENSIONS NC VERSION

DN	G	A	B	C	d	E	F	Wrench	Kv	Weight
mm.		mm.	mm.	mm.	mm.	mm.	mm.	mm.	m3/h	g.
15	1/2"	134	153	61	15	77	86	27	4.5	1180
20	3/4"	140	160	70	20	77	86	33	11	1200
25	1"	142	165	81	25	77	86	38	13	1400
32	1"1/4	183	211	95	32	100	111	49	30	2400
40	1"1/2	191	219	110	40	100	111	56	42	2820
50	2"	203	239	130	50	100	111	69	66	3680
65	2"1/2	239	244	149	65	100	114	86	82	5500
80	3"	247	263	174	80	100	114	110	98	6350